

# HOW TO INSTALL DOG MECHANISM COMPONENTS

## FOLLOW THESE THREE BASIC RULES

1. When the star drag mechanism is assembled in proper sequence, turn the Bridge slightly so that the dog and dog spring are easily inserted. Hold the side plate in an inverted position with the fingers of the left hand over the Bridge to hold the drag washers in position.

(See sketch on page 2 .)

2. Once the dog mechanism has been assembled, check to make sure the mechanism is clicking properly.

3. Long threaded screws always go into holes nearest Bridge stud. Short threaded screws go into other opening for clutch springs.

# ASSEMBLING CLUTCH

(All Penn Models except 130 and 349 series)

1. After assembling star-drag mechanism, place gear bridge (G) in position (1). Insert long threaded screw from front to hold dog (I).
2. Replace dog (I) and dog spring (J). To do this, grip end plate with your left hand, and with left thumb press gear bridge (G) against plate, having gear bridge turned toward the left (position 1) far enough to allow the dog and spring to be placed into position. After inserting the dog and spring, rotate (without releasing thumb pressure) the gear bridge to the right (position 2) so that the remaining gear bridge screw (H Long Threaded) may be screwed into gear bridge, followed by the two clutch yoke guide screws (K Short Threaded).

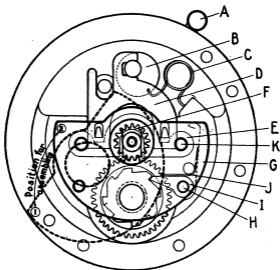

**155**

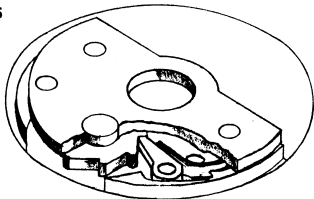

### **FOR PENN REEL MODELS 155 and 49**

Hold plate in an inverted position with left hand. Insert bridge screw from underneath. Hold screw in position with finger and place dog over bridge screw. Place flat spring firmly against the dog and bend slightly around the spring pin until the spring is positioned in plate. Don't overbend spring.

**49**

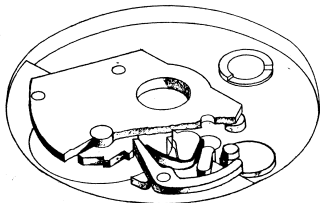

140

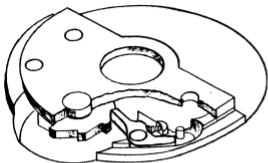

99

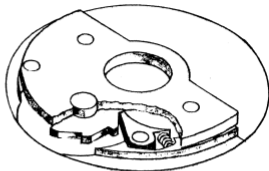

109

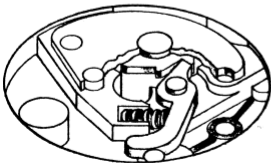

### FOR PENN REEL

### MODELS 140, 145, 146, 99, 109

Insert dog spring into hole located on side of dog (model 140-5-6 only). Models 99 and 109, insert spring after dog has been positioned. Hold plate in an inverted position with left hand and place one of the long threaded bridge screws into the plate from underneath. Hold screw in position with finger. Place dog with spring inserted (model 140-5-6) over screw and with small pointed object, compress dog spring until firmly placed against the plate embossment. Turn the Bridge slowly, keeping slight pressure on top of bridge to maintain drag washers in position. Insert remaining three bridge screws.

## PENN REEL MODEL 349 SERIES

Remove bridge assembly from plate. Place on flat surface so that ratchet side faces in upward position. Place dog over dog pin mounted on Bridge (the larger one). Place dog spring over spring pin. Compress spring until positioned against dog. Replace main gear and drag assembly. With plate in upright position, place over Bridge assembly and insert four bridge screws.

349

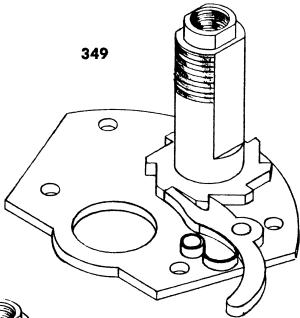

130

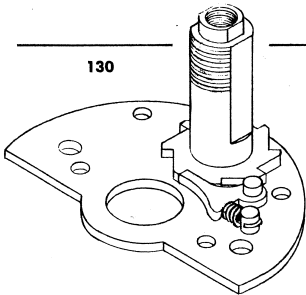

## PENN REEL MODEL 130

Procedure for assembling 130 dog is the same as that given for 349 series, with the exception of the dog spring. Insert dog spring first by placing spring loop over the spring pin and compressing until positioned against the dog.