

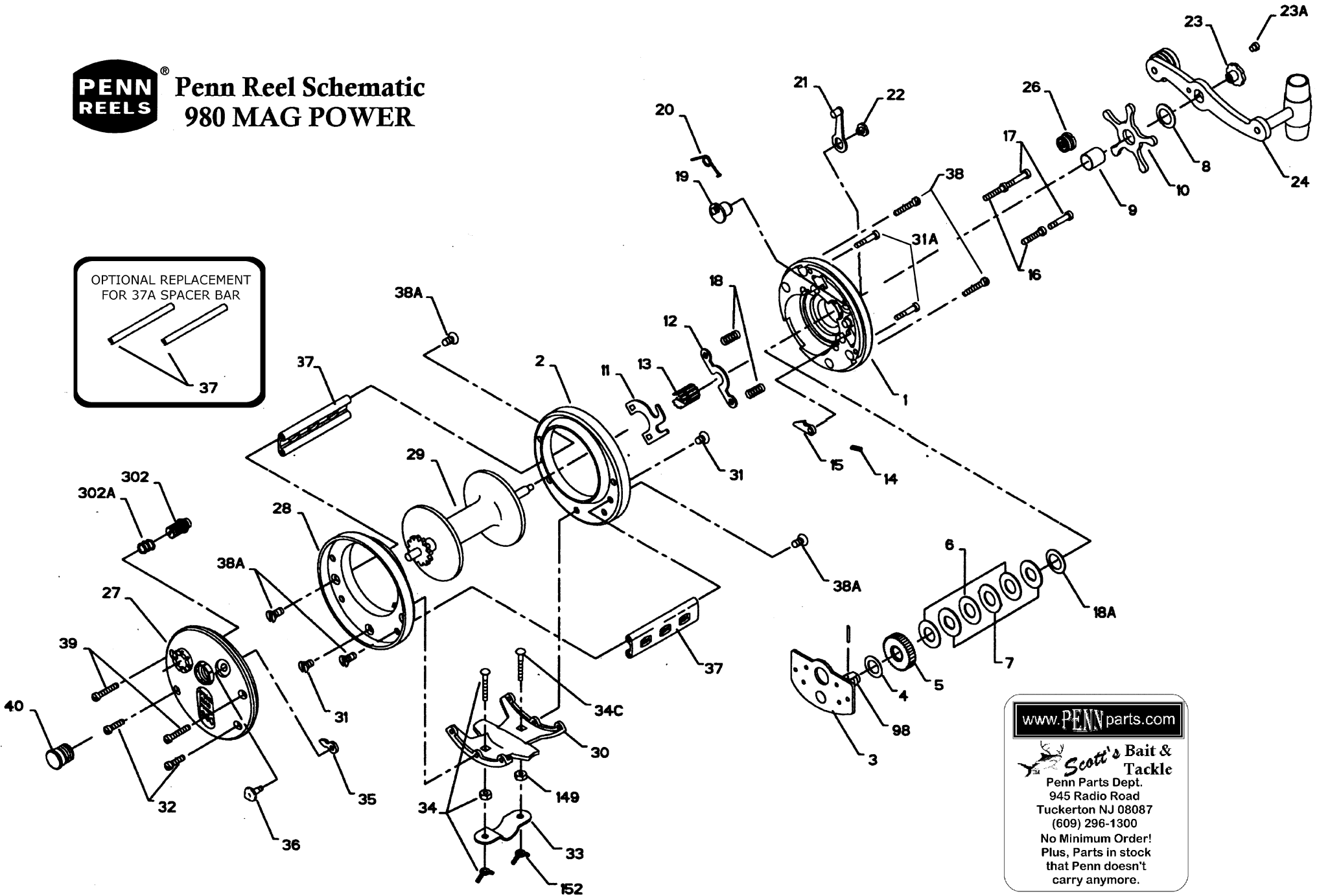

Penn Reel Schematic 980 MAG POWER

OPTIONAL REPLACEMENT
FOR 37A SPACER BAR

37



www.PENNparts.com

Scott's Bait & Tackle
Penn Parts Dept.
945 Radio Road
Tuckerton NJ 08087
(609) 296-1300
No Minimum Order!
Plus, Parts in stock
that Penn doesn't
carry anymore.

Penn Reel Parts list for Model: 980 Mag Power Reel

KEY NO.	PART NO.	DESCRIPTION	KEY NO.	PART NO.	DESCRIPTION
1	1-970	HANDLE SIDE PLATE	30	30N-980	STAND
2	2-970	HANDLE SIDE RING	31	31-19	STAND SCREW (CENTER)
3	3-970	BRIDGE W/SLEEVE	31A	31-970	HANDLE SIDE STAND SCREW
4	4-349	FIBER WASHER	32	39-6	NON-HANDLE SIDE STAND SCREW
5	5-970	MAIN GEAR	33	33-990	ROD CLAMP
6	6-113H	DRAG WASHER (3 REQ.)	34	34-200	ROD CLAMP SCREW
7	7C-970	WASHER (METAL SET)	35	35-155	CLICK TONGUE
8	8-349	TENSION SPRING	36	36-209	CLICK BUTTON
9	9N-970	SPACING SLEEVE	37	37-155	POSTS (OPTIONAL - 4 REQ.)
10	10-970	STAR DRAG WHEEL			CAN USE TWO 37'S IN PLACE OF ONE 37A
11	11-200	ECCENTRIC JACK	37A	37A-500	SPACER BAR (CONTROL)
12	12-155	PINION YOKE		37A-500	SPACER BAR (PENN)
13	13-970	PINION GEAR W/ RING	38	38-970	HANDLE SIDE UPPER SPACER BAR SCREW
14	14-99	DOG SPRING	38A	38A-970	INNER SPACER BAR SCREW
15	15-970	DOG	39	157A-12	OUTER SPACER BAR SCREW
16	16-60	LOWER BRIDGE SCREW	40	40-970	NON-HANDLE SIDE BEARING (COMPLETE)
17	17-60	UPPER BRIDGE SCREW	40A	40A-970	NON-HANDLE SIDE BEARING CUP
18	18-60	CLUTCH SPRING	40B	40B-970	NON-HANDLE SIDE BEARING PRESSURE PLUG
18A	18-970	CLUTCH SPRING	55	55-113H	HANDLE SIDE BEARING
19	19-200	ECCENTRIC CAM	55A	55-116	NON-HANDLE SIDE BEARING
20	20-155	ECCENTRIC SPRING	57	57-109	PRESSURE PLUG SPRING
21	21-200	ECCENTRIC LEVER	98	98-320	GEAR SLEEVE
22	22-99	ECCENTRIC SCREW	103	103-970	HANDLE SIDE BEARING CUP
23	23-114	HANDLE SCREW	110	110-60	HANDLE LOCK SCREW
24	24-970	HANDLE	149	149-200	ROD CLAMP HEX NUT
26	26-970	HANDLE SIDE BEARING (COMPLETE)	152	152-200	ROD CLAMP WING NUT
27	27-980	NON-HANDLE SIDE PLATE	157A	157A-12	UPPER SPACER BAR SCREW
28	2-970	NON-HANDLE SIDE RING	173	173-113H	HANDLE SIDE BEARING RETAINER
29	29L-980	SPOOL (COMPLETE)	173A	173-140	NON-HANDLE SIDE BEARING RETAINER
			302	302-970	MAGNET HOUSING W/ MAGNET
			302A	302A-970	HOUSING SPRING MAGNET

NOTE: Many of www.pennparts.com schematics include changes that were either made by Penn, or errors found and corrected by our parts dept.
SBT Ver. 070415

CLICKER RELATED NOTES/PART CHANGE INFO

INSTALLATION:

To replace the click tongue on models where it is peened into place, use a dremel drill with a fine tip to remove the old click tongue and click button. Then peen the new 36-209 into place.

OPTIONAL:

Any reel that uses the 36-209 button can use:

36N-209 button and a 69B-600 removable c clip

This newer style is held by the clip instead of being peened in place.