

68 Long Beach

Remove old click button using dremel drill and peen new button into place

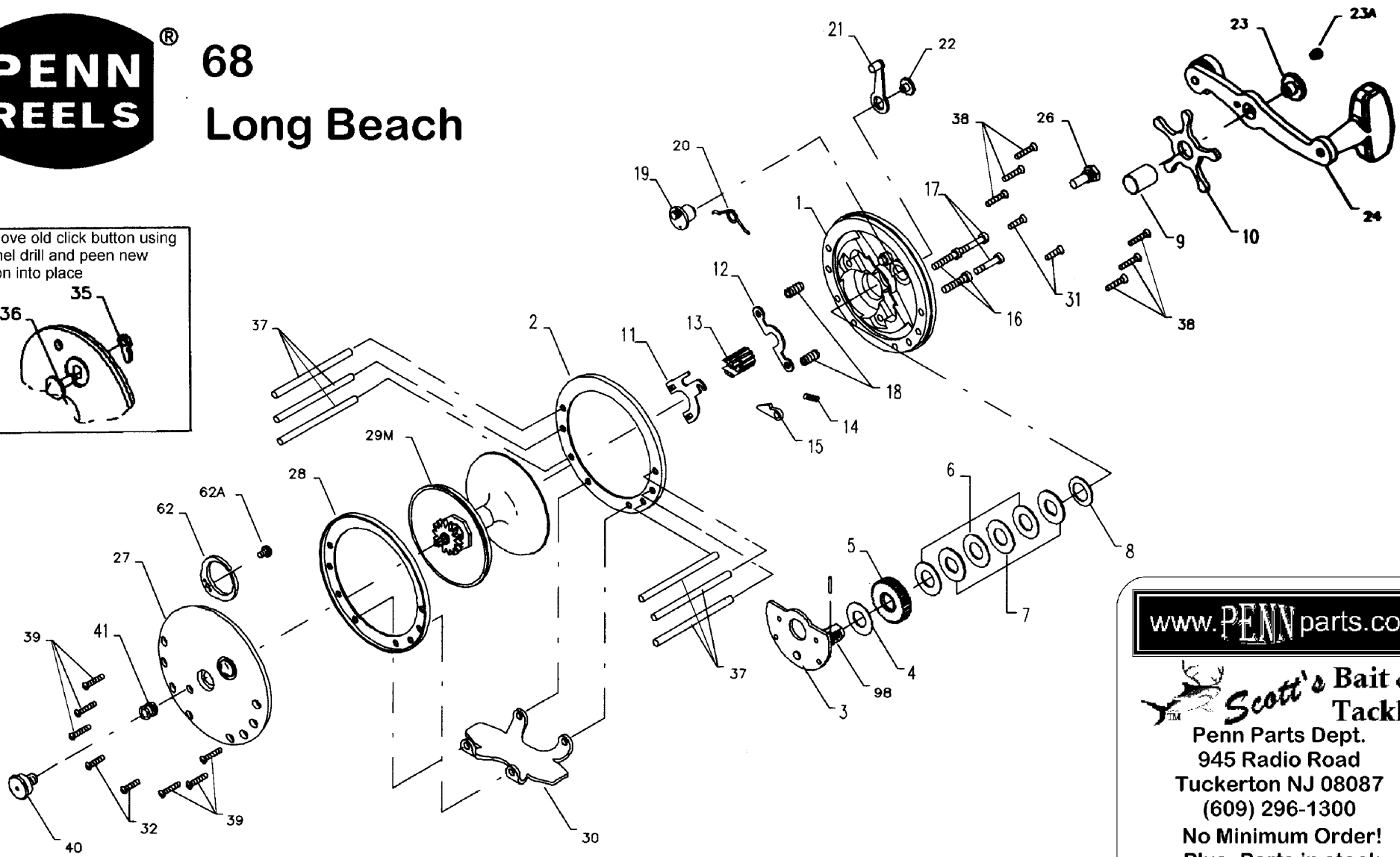

www.PENNparts.com

Scott's Bait & Tackle
 Penn Parts Dept.
 945 Radio Road
 Tuckerton NJ 08087
 (609) 296-1300
 No Minimum Order!
 Plus, Parts in stock
 that Penn doesn't
 carry anymore.

Penn Reel Parts list for Model: 68 Longbeach

KEY PART	KEY PART	DESCRIPTION	KEY PART	DESCRIPTION	
NO	NO.		NO		
1	1-68	RIGHT SIDE PLATE	24	24-66	HANDLE
2	2-66	RIGHT SIDE RING	26	26-60	RIGHT SIDE BEARING
3	3-66	BRIDGE W/ SLEEVE	27	27-66	LEFT SIDE PLATE
4	4-60	FIBER WASHER	28	2-66	LEFT SIDE RING
5	5-66	MAIN GEAR	29	29M-68	SPOOL
6	6-113	DRAG WASHER (3 REQ.)	30	30-68	STAND
7	7C-60	METAL WASHER	31	38-8	RIGHT SIDE STAND SCREW (2 REQUIRED)
8	8-60	TENSION SPRING	32	32-16CH	LEFT SIDE STAND SCREW (2 REQUIRED)
9	9-66	SPACING SLEEVE	33	33N-113	ROD CLAMP (THICK GRAPHITE)
10	10-66	STAR DRAG WHEEL	*	33R-200	ROD CLAMP, METAL RINGED (OPTIONAL)
11	11-66	ECCENTRIC JACK	34	34-45	CLAMP SCREW ONLY
12	12-60	PINION YOKE	34C	34C-45	ROD CLAMP SCREW W/ NUTS
13	13-49	PINION	35	35-60	CLICK TONGUE
14	14-99	DOG SPRING	36	36-209	CLICK BUTTON **** read design change note below!
15	15-99	DOG	37	37-113HLW	FRAME POST (6 REQUIRED)
16	16-60CH	LOWER BRIDGE SCREW (2 REQ.)	38	39-6	RIGHT SIDE POST SCREW (6 REQUIRED)
17	17-60CH	UPPER BRIDGE SCRW (2 REQ.)	39	39-5	LEFT SIDE POST SCREW (6 REQUIRED)
18	18-60	CLUTCH SPRING (2 REQ.)	40	40-60	LEFT SIDE BEARING
19	19-60	ECCENTRIC	41	41-60	LEFT SIDE BEARING SPRING
20	20-60L	ECCENTRIC SPRING	62	62-309	CLICK SPRING
21	21-66	ECCENTRIC LEVER	62A	63-209	CLICK SPRING SCREW
22	22-60CH	ECCENTRIC SCREW	98	98-60	GEAR SLEEVE
23	23-60	HANDLE SCREW	149	149-45	LONG CLAMP NUT
23A	110-60	HANDLE LOCK SCREW	149A	149-200	HEX NUT
			*	152-200	WING NUT - USE INSTEAD OF 149-45 WITH 33R-200 CLAMP

* NOT SHOWN

NOTE: Many of www.pennparts.com schematics include changes that were either made by Penn, or errors found and corrected by our parts dept.
SBT Ver. 070415

Change: Older reels prior to 1953 used the 14-60 bent copper dog spring.
After 1953, this changed to the current 14-99 coiled dog spring.

CLICKER RELATED NOTES/PART CHANGE INFO

INSTALLATION:

To replace the click tongue on models where it is peened into place, use a dremel drill with a fine tip to remove the old click tongue and click button. Then peen the new 36-209 into place.

OPTIONAL:

Any reel that uses the 36-209 button can use:

36N-209 button and a 69B-600 removable c clip

This newer style is held by the clip instead of being peened in place.

***** IMPORTANT DESIGN CHANGE NOTE (MEASURE!)

On older 66, 67 and 68 reels a 36-60CH may be required. It measures .248 (roughly 1/4 inch) from just under the cap to the edge of the dropdown.

The 36-209 measures .283 (roughly 1/16 inch longer) Penn may have changed the

27-66 plate (Used on 66, 67, and 68) at some point, although there are no notes to that effect.