

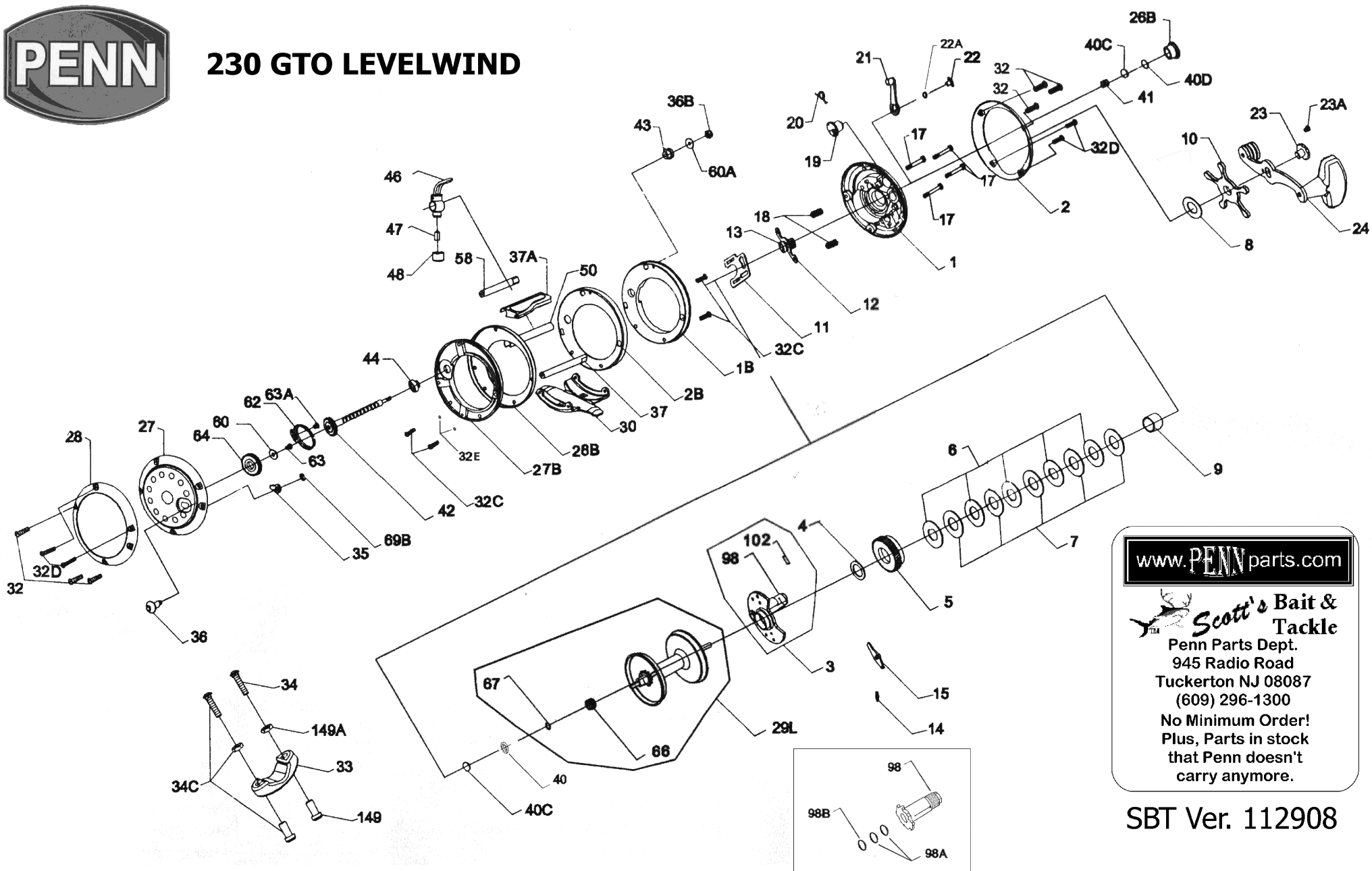

230 GTO LEVELWIND



www.PENNparts.com

Scott's Bait & Tackle
Penn Parts Dept.
945 Radio Road
Tuckerton NJ 08087
(609) 296-1300
No Minimum Order!
Plus, Parts in stock
that Penn doesn't
carry anymore.

SBT Ver. 112908

Penn Reel Parts list for: 230GTO

KEY NO	PART NO.	DESCRIPTION	KEY NO	PART NO.	DESCRIPTION
1	1-230	R S OUTER PLATE	**32DA	32DA-220	LINE GUIDE SHAFT SCREW - LONG (2 REQ.)
1B	1B-230	R S INNER PLATE	32E	32E-220	STAND SCREW WASHER (4 REQ.)
2	2-230	R S OUTER RING	33	33-220	ROD CLAMP
2B	2B-230	R S INNER RING	34	34-220	CLAMP SCREW (2 REQ.)
3	3-230	BRIDGE ASSEMBLY	34C	34C-220	CLAMP SCREW W/NUTS (2 REQ.)
4	4-349	FIBER WASHER	35	35-230	CLICK TONGUE
5	5-220	MAIN GEAR	36	36-230	CLICK BUTTON
6	6-320	FRICTION DRAG WASHER (5 REQ.)	36B	36B-220	WORM SHAFT NUT
7	7C-220	METAL DRAG WASHER SET	37	37-220	FRAME POST
8	8-220	TENSION SPRING	37A	37A-230	TOP SPACER BAR ("230")
9	9-220	SPACING SLEEVE	40	40-220	BALL BEARING
10	10-220	STAR DRAG	40C	40C-220	METAL THRUST WASHER (2 REQ.)
11	11-230	ECCENTRIC JACK	40D	40D-220	RUBBER THRUST WASHER
12	12-230	PINION YOKE	41	41-220	R S THRUST BEARING SPRING
13	13-230	PINION GEAR	42	42-230	WORM
14	14-220	DOG SPRING	43	43-220	R S WORM BUSHING (old #43-230)
15	15-230	DOG	44	44-230	L S WORM BUSHING
17	17-220	BRIDGE SCREW (4 REQ.)	46	46-230	LINE GUIDE CARRIAGE
18	18-220	CLUTCH SPRING (2 REQ.)	47	47-220	PAWL
19	19-230	ECCENTRIC CAM	48	48-220	PAWL COVER SCREW
20	20-230	ECCENTRIC SPRING	50	50-220	WORM SHIELD
21	21-230	ECCENTRIC LEVER	58	58-230	SLOTTED POST
22	22-220	ECCENTRIC SCREW	60	60-220	IDLER GEAR WASHER
22A	22A-220	ECCENTRIC SCREW WASHER	60A	60A-220	WORM NUT WASHER
23	23-220	HANDLE SCREW	62	62-220	CLICK SPRING
23A	23A-220	HANDLE LOCK SCREW	63	63-220	CLICK SPRING SCREW (2 REQ.)
24	24-230	HANDLE	64	64-230	IDLER GEAR
26B	26B-230	SPOOL TENSION CONTROL CAP	66	66-220	SPOOL GEAR
27	27-230	L S OUTER PLATE	67	67-220	SPOOL GEAR LOCK RING
27B	27B-230	L S INNER PLATE	69B	69B-220	RETAINING RING F/CLICK BUTTON
28	28-230	L S OUTER RING	98	98-220	GEAR SLEEVE
28B	28B-230	L S INNER RING	**98A	98A-220	GEAR STUD SHIM (2 REQ.)
29L	29L-230	SPOOL, ALUMINUM	**98B	98B-220	GEAR STUD SHIM (1 REQ.)
30	30-230	STAND	102	102-220	GEAR SLEEVE PIN
32	32-220	SIDE PLATE SCREW (4 REQ.)	149	149-220	CLAMP NUT (2 REQ.)
32C	32C-220	STAND SCREW (4 REQ.)	149A	149A-220	HEX NUT (2 REQ.)
32D	32D-220	LINE GUIDE SHAFT SCREW - SHORT (2 REQ.)			

NOTE: Many of www.pennparts.com schematics include changes that were either made by Penn, or errors found and corrected by our parts dept.
SBT Ver. 091814

NOTES ** PARTS THAT ARE IN THE REEL BUT NOT ON THE DRAWING OR THE LIST FROM PENN NUMBERS MAY BE CORRECTED WHEN PENN ACKNOWLEDGES THEM

32DA-220 CAN BE SUBBED WITH THE SHORTER 32D-220 PER PENN
58-230 is NOT interchangeable with 58-220, despite previous schematic versions.