

180
no actual schematic available
using 155L schematic as parts lists match

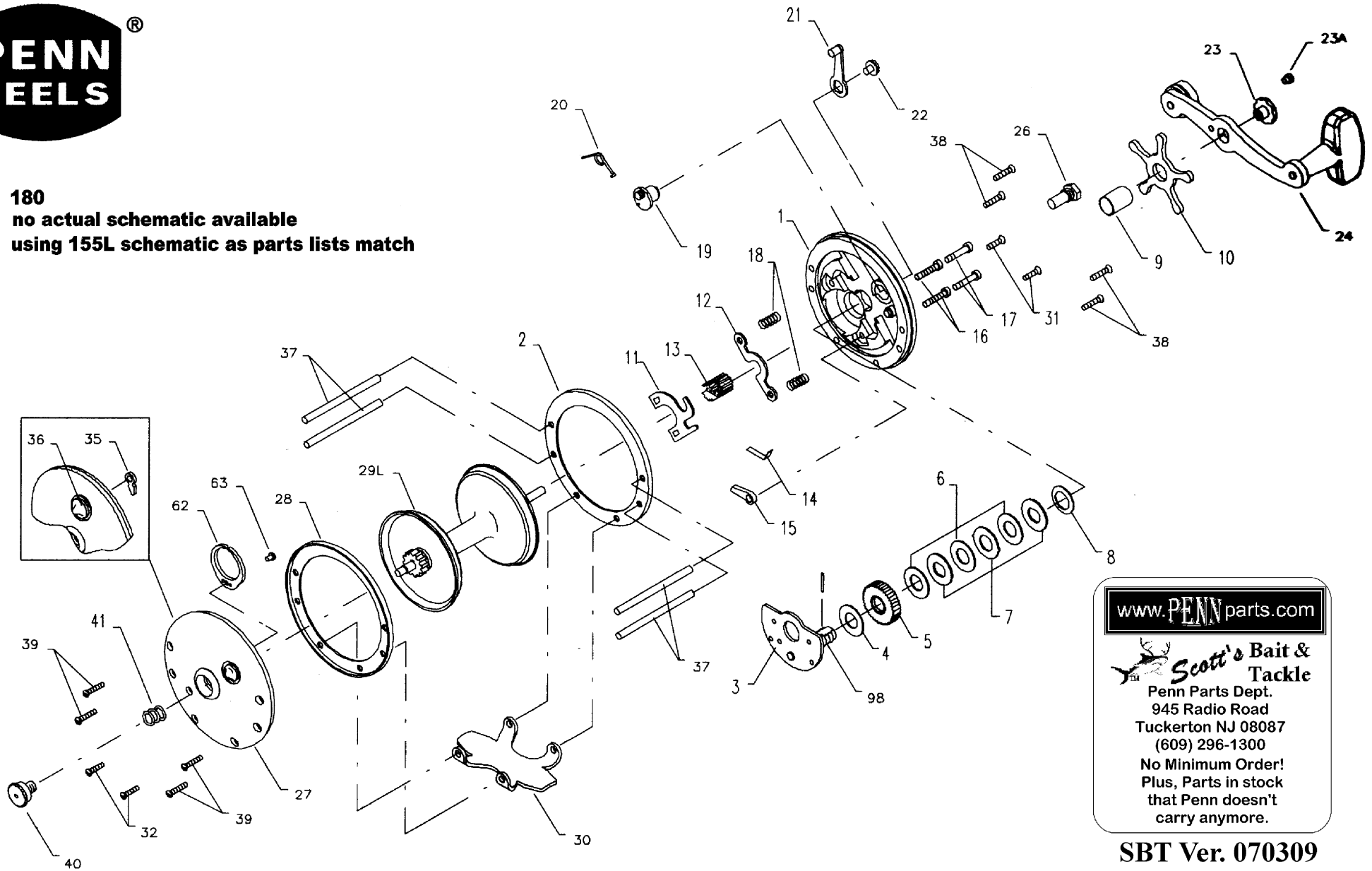

www.PENNparts.com

Scott's Bait & Tackle
Penn Parts Dept.
945 Radio Road
Tuckerton NJ 08087
(609) 296-1300

No Minimum Order!
Plus, Parts in stock
that Penn doesn't
carry anymore.

SBT Ver. 070309

Penn Reel Parts list for: Model: 180

KEY PART			KEY PART		
NO	NO.	DESCRIPTION	NO	NO.	DESCRIPTION
1	1-180	RIGHT SIDE PLATE	20	20-155	ECCENTRIC SPRING
2	2-155	RIGHT SIDE PLATE	21	21-155	ECCENTRIC LEVER
3	3-155	BRIDGE W/ SLEEVE	22	22-60CH	ECCENTRIC SCREW
4	4-155	FIBER WASHER	23	23-180	HANDLE SCREW
5	5-155	MAIN GEAR	23A	110-60	HANDLE LOCKING SCREW
6	6-155	DRAG WASHER (3 REQ.)	24	24-160	HANDLE
7	7C-155	METAL WASHER SET	26	26-155	RIGHT SIDE BEARING
8	8-60	TENSION SPRING	27	27-155	LEFT SIDE PLATE
9	9-60	SPACING SLEEVE	28	2-155	LEFT SIDE PLATE
10	10-180	STAR DRAG WHEEL	29	29L-100	SPOOL
11	11-155	ECCENTRIC JACK	30	30-180S	STAND
12	12-155	PINION YOKE	31	32-22	R.S. STAND SCREW (2 REQ.)
13	13-155	PINION	32	32-14CH	L.S. STAND SCREW (2 REQ.)
14	14-155	DOG SPRING	35	35-155	CLICK TONGUE
15	15-155	DOG	36	36-155CH	CLICK BUTTON
16	16-60	LOWER BRIDGE SCREW	37	37-180	FRAME POST
17	17-60CH	UPPER BRIDGE SCREW	38	38-8	RIGHT SIDE PLATE SCREW (4 REQ.)
18	18-60	CLUTCH SPRING	39	39-4	LEFT SIDE POST SCREW (4 REQ.)
19	19-155	ECCENTRIC	40	40-60	LEFT SIDE BEARING
			41	41-60	LEFT SIDE BEARING SPRING

NOTE: Many of www.pennparts.com schematics include changes that were either made by Penn, or errors found and corrected by our parts dept.
 SBT Ver. 070309