

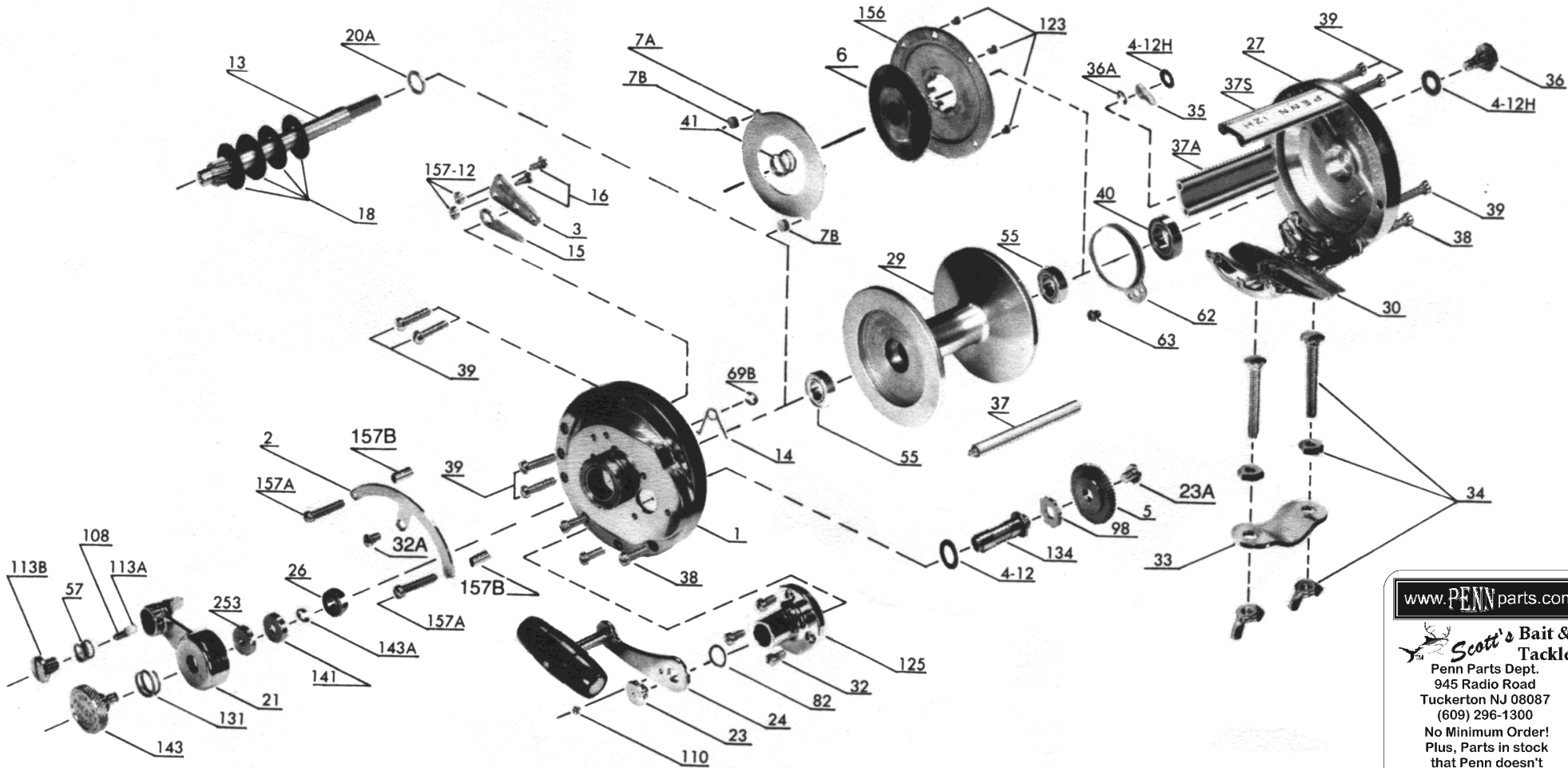

# PARTS LIST FOR INTERNATIONAL 12H



[www.PENNparts.com](http://www.PENNparts.com)

**Scott's Bait & Tackle**

Penn Parts Dept.  
945 Radio Road  
Tuckerton NJ 08087  
(609) 296-1300

No Minimum Order!  
Plus, Parts in stock  
that Penn doesn't  
carry anymore.

Penn Reel Parts list for:

**KEY PART**

<b>NO</b>	<b>NO.</b>	<b>DESCRIPTION</b>
1	1-12	RIGHT SIDE PLATE ASSEMBLY
2	2-6	QUADRANT
3	3-6	RATCHET DOG BRIDGE
4-12H4-12H		CLICK BUTTON WASHERS (2 Req.)
4-12	4-12	GEAR STUD WASHER
5	5-12H	MAIN GEAR
6	117-12T	DRAG WASHER/DRIVE PLATE
7A	7A-6	METAL EAR DRAG WASHER
7B	7B-12H	PRESSURE PLUGS (2 Req.)
13	13-12H	PINION GEAR
14	14-6	DOG SPRING
15	15-6	DOG RATCHET
16	16-6	BRIDGE SCREWS (2 REQ. Req.)
18	18-12T	DISC CLUTCH SPRINGS (4 Req.)
20A	20A-12H	THRUST WASHER
21	21-6	DRAG LEVER
23-A	23-6	GEAR MTG. SCREW
23	23-60	HANDLE SCREW
24	24-12H	HANDLE COMPLETE
26	55-6	RIGHT SIDE BEARING
27	27-12H	LEFT SIDE PLATE ASSEMBLY
29	29L-12T	SPOOL
30	30-99	STAND
32	32-14	GEAR STUD HOUSING SCREWS (3 Req.)
32-A	110-50	QUADRANT SCREW
33	33-200	ROD CLAMP
33R	33R-200	RINGED ROD CLAMP
34	34C-200	CLAMP SCREW W/ NUTS
35	35-155	CLICK TONGUE
36	36-12H	CLICK BUTTON
36A	69B-50	RETAINING RING

Model: 12H

**KEY PART**

<b>NO</b>	<b>NO.</b>	<b>DESCRIPTION</b>
37	37-12	FRAME POST
37A	37A-12	SPACER BAR
37S	37S-12H	STAMPED SPACER BAR
38	38-8	STAND SCREWS (6 Req.)
39	39-6	SPACER SCREWS (4 Req.)
40	55-12H	LEFT SIDE PLATE BEARING
41	57-109	BEARING SPRING
55	20-722	SPOOL BEARINGS (2 Req.)
57	57-109	DRAG LEVER SPRING
62	62-309	CLICK SPRING
63	63-209	CLICK SPRING SCREW
69B	69B-50	RETAINING RING
82	82-6	HANDLE SHIM
98	98-6	MAIN GEAR RATCHET
108	108-140	DRAG LEVER BUTTON SPRING
110	110-60	HANDLE LOCK SCREW
113A	113A-6	DRAG LEVER BUTTON
113B	113B-6	DRAG LEVER SCREW
123	123-50	DRAG COVER SCREWS (4 Req.)
125	125-6	GEAR STUD HOUSING
131	131-6	PRE-SET SPRING
134	134-12H	MAIN GEAR STUD
141	141-6	LEVER FOLLOWER
143	143-6	PRE-SET KNOB
143A	143A-6	RETAINING RING
156	156-12H	DRAG WASHER COVER
157-B	157-12T	QUADRANT SPACER BUSHING (2 Req.)
157	157-12	RATCHET DOG BRIDGE BUSHINGS(2 Req.)
157-A	16-9	QUADRANT SCREW
253	253-12	THRUST BEARING

NOTE: Many of www.pennparts.com schematics include changes that were either made by Penn, or errors found and corrected by our parts dept.

**last update 4/7/03**