

PENN® PARTS LIST FOR MODEL CV2 5000

www.PENNparts.com

Scott's Bait & Tackle
 Penn Parts Dept.
 945 Radio Road
 Tuckerton NJ 08087
 (609) 296-1300
 No Minimum Order!
 Plus, Parts in stock
 that Penn doesn't
 carry anymore.

SBT Ver. 053109
 Based on Penn's Rev 7/18/08

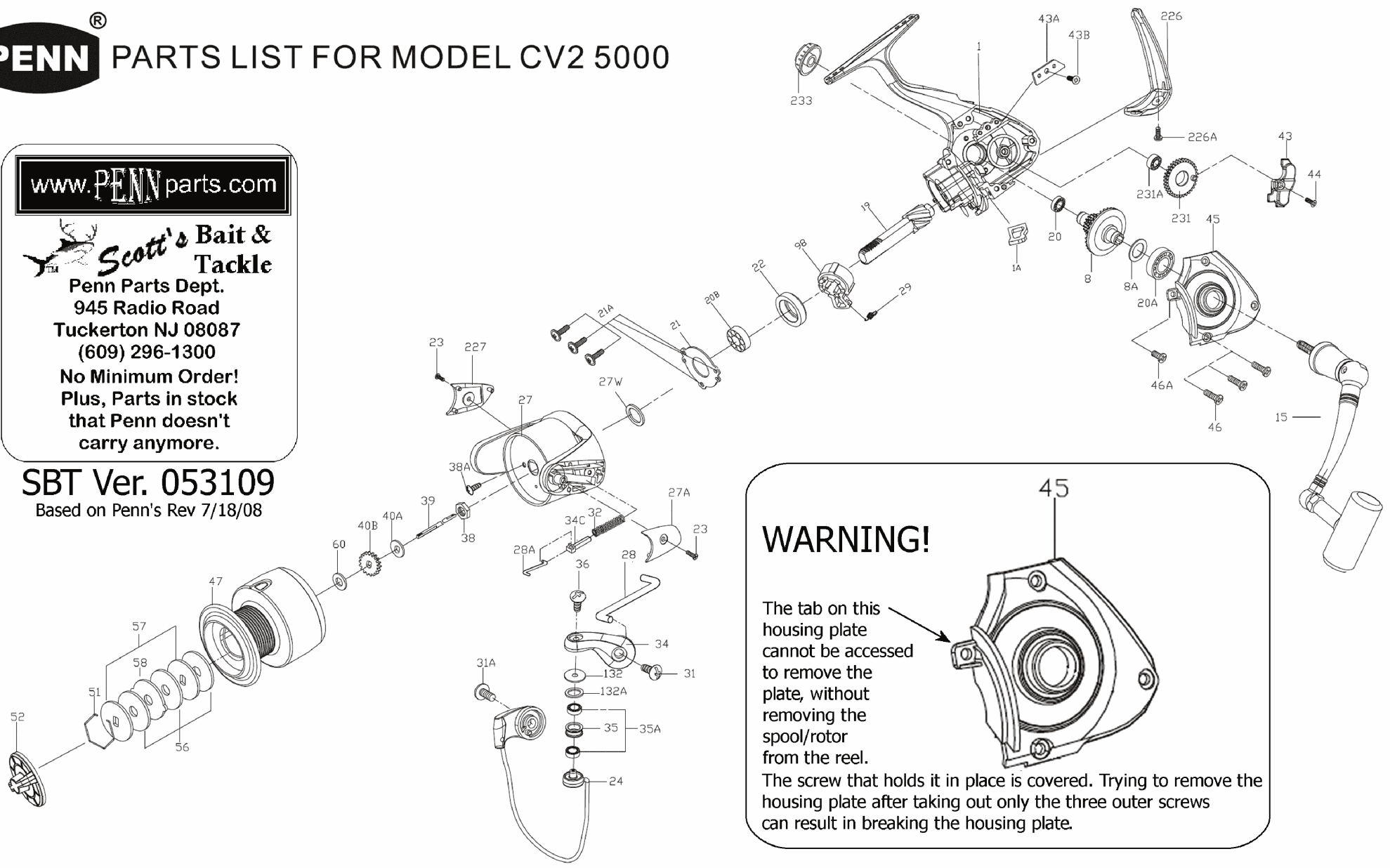

WARNING!

The tab on this housing plate cannot be accessed to remove the plate, without removing the spool/rotor from the reel.

The screw that holds it in place is covered. Trying to remove the housing plate after taking out only the three outer screws can result in breaking the housing plate.

Penn Reel Parts list for:

Model: CV2 5000 Captiva

KEY NO	PART NO.	DESCRIPTION	KEY NO	PART NO.	DESCRIPTION
1	1-5000CV2	HOUSING	38	38-5000CV2	ROTOR NUT
1A	1A-5000CV2	HOUSING INSERT	38A	38A-2000CV2	ROTOR NUT SCREW
8	8-5000CV2	MAIN GEAR ASSEMBLY	39	39-5000CV2	SPOOL SHAFT
8A	8A-4000CV2	MAIN GEAR SHIM (USES 1 OR 2)	40A	40A-5000CV2	SPOOL SHAFT WASHER
15	15-5000CV2	HANDLE ASSEMBLY	40B	40B-5000CV2	CLICK RATCHET
19	19-5000CV2	PINION GEAR	43	43-5000CV2	CROSSWIND BLOCK
20	20-5000CV2	HOUSING BALL BEARING	43A	43A-5000CV2	CROSSWIND BLOCK PLATE
20A	20A-4000CV2	HOUSING COVER BALL BEARING	43B	43B-2000CV2	CROSSWIND PLATE SCREW
20B	20B-5000CV2	PINION BALL BEARING	44	44-5000CV2	CROSSWIND BLOCK SCREW
21	21-5000CV2	BEARING RETAINER	45	45-5000CV2	HOUSING COVER
21A	21A-2000CV2	BEARING RETAINER SCREW (USES 3)	46	46-5000CV2	HOUSING COVER SCREW (USES 3)
22	22-5000CV2	COLLAR	46A	46A-5000CV2	SHORT HOUSING COVER SCREW FOR TA
23	23-2000CV2	ROTOR SIDE COVER SCREWS (USES 2)	47	47-5000CV2	SPOOL ASSEMBLY
24	24-5000CV2	BAIL WIRE	51	51-5000CV2	RETAINING RING
27	27-5000CV2	ROTOR CUP	52	52-5000CV2	DRAG KNOB
27A	27A-5000CV2	BAIL PIVOT COVER	56	56-5000CV2	FRICTION DRAG WASHER (USES 3)
27W	27W-5000CV2	ROTOR WASHER	57	57-5000CV2	KEYED WASHER (USES 2)
28	28-5000CV2	TRIP LEVER	58	58-5000CV2	EARED DRAG WASHER
28A	28A-5000CV2	TRIP LEVER LINK	60	60-5000CV2	THRUST WASHER
29	29-2000CV2	SPRING	98	98-5000CV2	CLUTCH RETAINER & SLEEVE
31	31-2000CV2	BAIL ARM SCREW	132	132-4000CV2	LINE ROLLER BUSHING
31A	31A-2000CV2	BAIL WIRE SCREW	132A	132A-2000CV2	LINE ROLLER WASHER
32	32-5000CV2	BAIL SPRING	226	226-5000CV2	REAR CAP
34	34-5000CV2	BAIL ARM	226A	226A-5000CV2	REAR CAP SCREW
34C	34C-5000CV2	PIVOT ARM	227	227-5000CV2	BAIL CAM COVER
35	35-4000CV2	LINE ROLLER	231	231-5000CV2	CROSSWIND GEAR
35A	35A-2000CV2	LINE ROLLER BALL BEARING (USES 2)	231A	231A-5000CV2	CROSSWIND GEAR BALL BEARING
36	36-4000CV2	BAIL STUD SCREW	233	233-5000CV2	BEARING COVER

NOTE: Many of www.pennparts.com schematics include changes that were either made by Penn, or errors found and corrected by our parts dept.

SBT Ver. 053109 (based on Penn's Rev.7/18/08)

NOTE: BOTH THE ROTOR NUT AND THE HANDLE COLLAR
HAVE REVERSE THREADS
INSTALL BY TURNING COUNTER-CLOCKWISE