

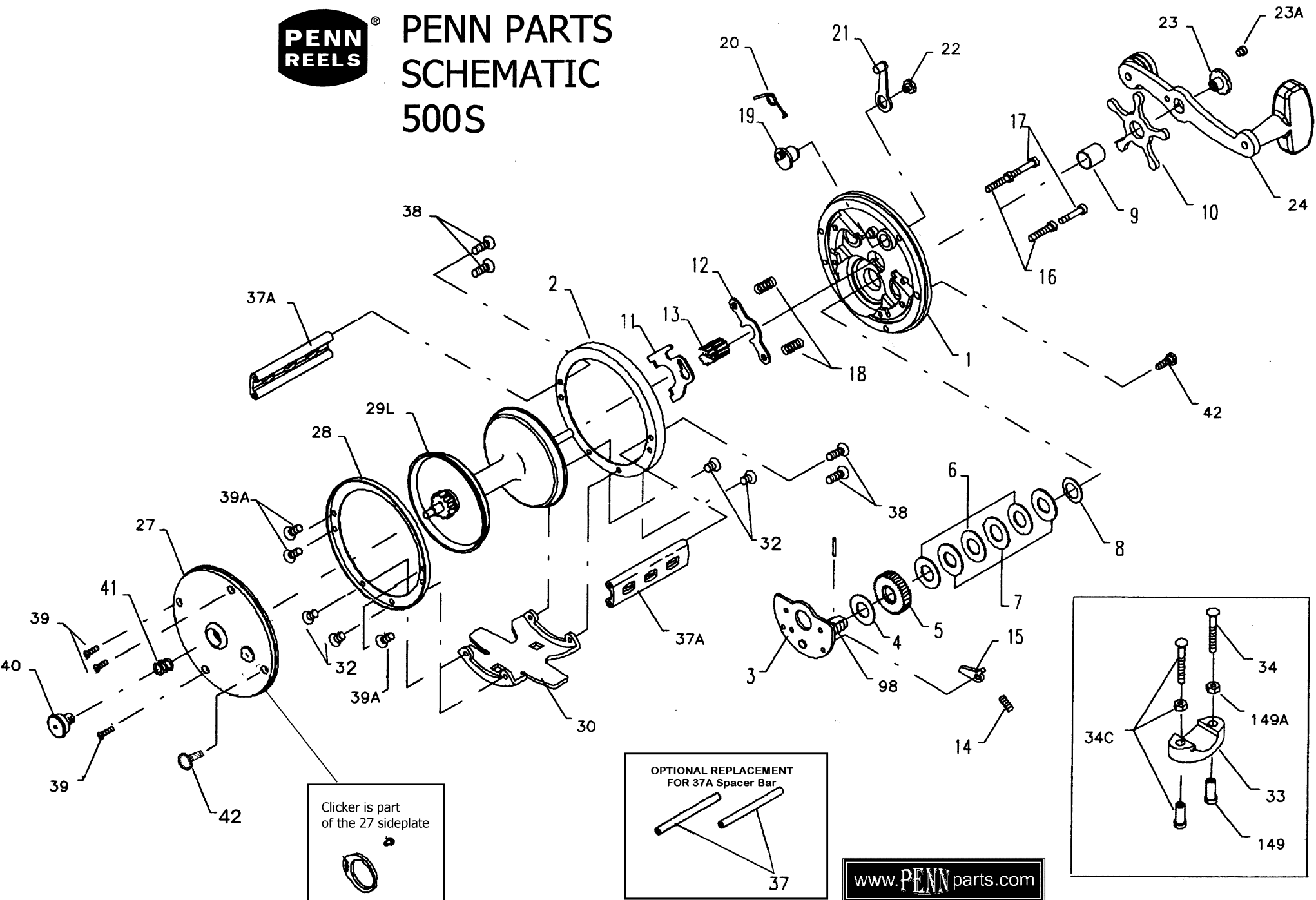



PENN PARTS SCHEMATIC 500S



Clicker is part
of the 27 sideplate



OPTIONAL REPLACEMENT
FOR 37A Spacer Bar

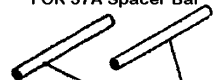

37

www.PENNparts.com

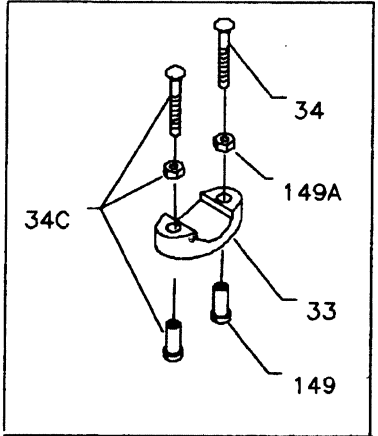

Penn Reel Parts list for Model: 500S Jigmaster Red

KEY PART			KEY PART		
NO	NO.	DESCRIPTION	NO	NO.	DESCRIPTION
1	1-500S	HANDLE SIDE PLATE (RED)	27	27-500S	NON-HANDLE SIDE PLATE (RED)
2	2-500S	HANDLE SIDE RING (INNER)	28	28-500S	NON-HANDLE SIDE RING (INNER)
3	3-500S**	BRIDGE W/ SLEEVE	29L	29L-500	SPOOL
4	4-60	FIBER WASHER	30	30-200	STAND
5	5-500	MAIN GEAR	32	32-15	INNER STAND SCREWS (4 REQ.)
6	6-309	DRAG WASHER (3 REQ.)	33	33-113	ROD CLAMP
7	7C-500	METAL WASHER SET	*	33R-200	METAL RINGED ROD CLAMP (OPTIONAL)
8	8-60	TENSION SPRING	34	34-45	CLAMP SCREW (ONLY)
9	9-60	SPACING SLEEVE	34C	34C-45	ROD CLAMP SCREW W/ NUTS F/GRAPHITE CLAMP
10	10-505***	STAR DRAG WHEEL	35	35-60	CLICK TONGUE
11	11-99	ECCENTRIC JACK	36	36-60CH	CLICK BUTTON
12	12-500	PINION YOKE	37	37-155	POSTS (OPTIONAL - 4 REQ.)
13	13-500	PINION			CAN USE TWO 37'S IN PLACE OF ONE 37A
14	14-500	DOG SPRING	37A	37A-500S	SPACER BAR (2 REQ.)
15	15-500	DOG	38	38-8	HANDLE SIDE OUTER SPACER SCREW (4 REQ.)
16	16-60CH	LOWER BRIDGE SCREW	39	46A-704	NON-HANDLE SIDE INNER SPACER SCREW (3 REQ.)
17	17-60CH	UPPER BRIDGE SCREW	39A	46A-704	NON-HANDLE SIDE OUTER RING SCREW (3 REQ.)
18	18-60	CLUTCH SPRING	40	40-60	NON-HANDLE SIDE BEARING
19	19-99	ECCENTRIC	41	41-60	BEARING SPRING
20	20-60L	ECCENTRIC SPRING	42	129-200	TAKE APART THUMB SCREW
21	21-66	ECCENTRIC LEVER	62	62-309	CLICK SPRING
22	22-99	ECCENTRIC SCREW	63	63-209	CLICK SPRING SCREW
23	23-60	HANDLE SCREW	98	98-505****	GEAR SLEEVE
23A	110-60	HANDLE LOCK SCREW	149	149-45	CLAMP NUT F/GRAPHITE CLAMP (2 REQ.)
24	24-66	HANDLE	149A	149-200	HEX NUT (2 REQ.)
26	26-155	RIGHT SIDE PLATE (RED)	*	152-200	WING NUT F/METAL RING CLAMP

* Not Shown

** Fine tooth sleeve, older reels take a 3-500S with a coarse tooth sleeve, bridge will still be stamped 3500s

*** Fine tooth star drag, older reels take a 10-60 or 10-140 with a coarse thread

**** Fine tooth gear sleeve, older reels take a 98-60 with a coarse thread

NOTE: Many of www.pennparts.com schematics include changes that were either made by Penn, or errors found and corrected by our parts dept.

SBT Version 052506