

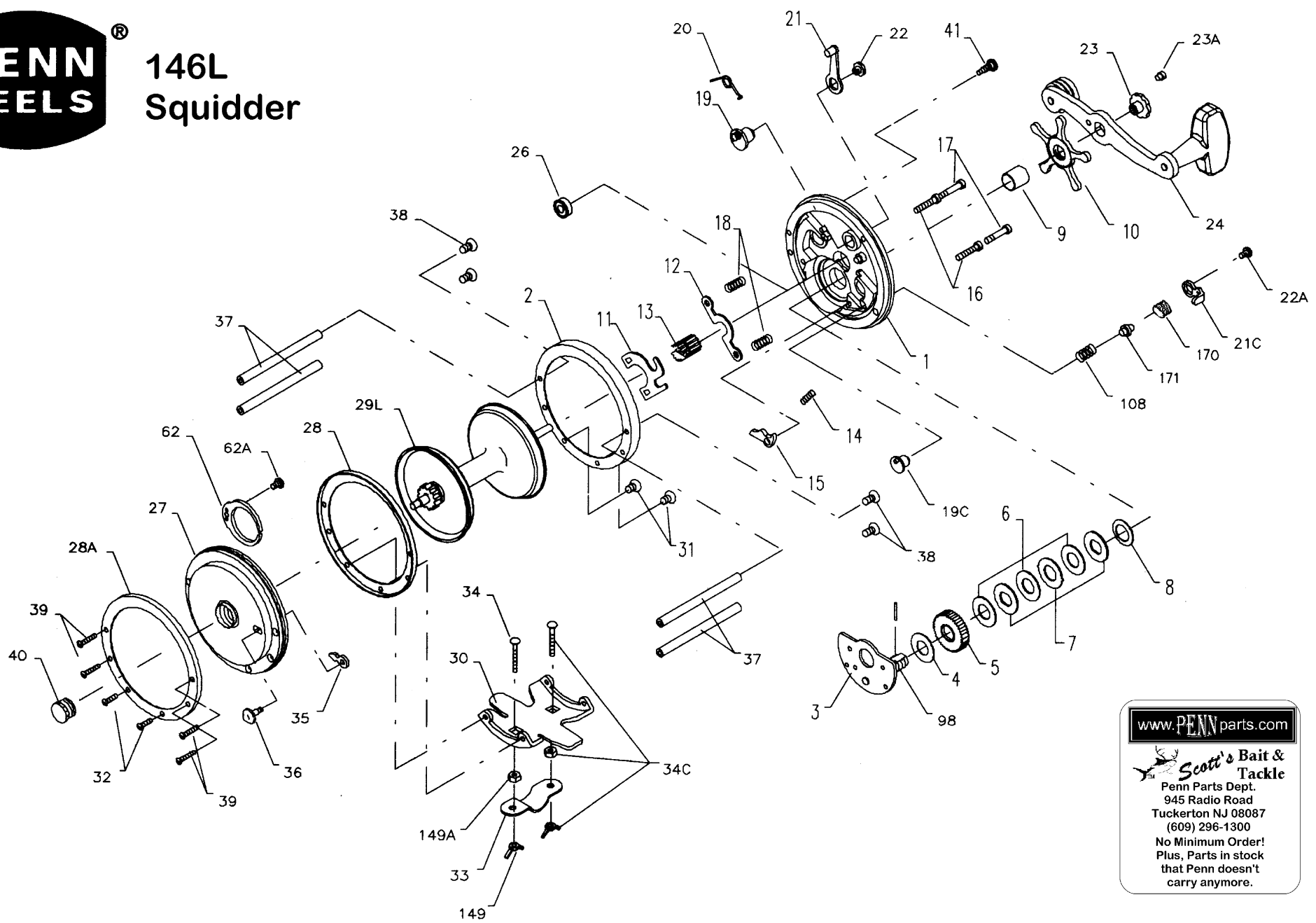

146L Squidder



www.PENNparts.com

Scott's Bait & Tackle
Penn Parts Dept.
945 Radio Road
Tuckerton NJ 08087
(609) 296-1300
No Minimum Order!
Plus, Parts in stock
that Penn doesn't
carry anymore.

Penn Reel Parts list for:

Model: 146L SQUIDDER

KEY PART			KEY PART		
NO	NO.	DESCRIPTION	NO	NO.	DESCRIPTION
1	1-146	RIGHT SIDE PLATE	23A	110-60	HANDLE LOCK SCREW
2	2-200	R.S. RING	24	24-155	HANDLE
3	3-200	BRIDGE W/ SLEEVE	26	26-140	R.S. BEARING
4	4-155	FIBER WASHER	27	27-140	LEFT SIDE PLATE
5	5-60	MAIN GEAR	28A	28-140-O	OUTER LEFT SIDE RING
6	6-60	DRAG WASHER (3 REQ.)	28	2-155	INNER LEFT SIDE RING
7	7C-60	METAL WASHER SET	29L	29L-146	SPOOL
8	8-60	TENSION SPRING	30	30-49	STAND
9	9-60	SPACING SLEEVE	31	31-19	STAND SCREW (R.S.)
10	10-140	STAR DRAG WHEEL	32	32-18	STAND SCREW (L.S.)
11	11-200	ECCENTRIC JACK	33	33-49	ROD CLAMP
12	12-155	PINION YOKE	34	34-49	CLAMP SCREW (2 REQ.)
13	13-140	PINION	34C	34C-49	ROD CLAMP SCREW W/ NUTS
14	14C-140	DOG SPRING	35	35-155	CLICK TONGUE
15	15-140	DOG	36	36-155CH	CLICK BUTTON
16	16-60CH	LOWER BRIDGE SCREW	37	37-180	FRAME POST
17	17-60CH	UPPER BRIDGE SCREW	38	38-7	R.S. POST SCREW
18	18-60	CLUTCH SPRING (2 REQ.)	39	39-9	L.S. POST SCREW
19	19-200	ECCENTRIC	40	40-140	L.S. BEARING
19C	19-140S	ECCENTRIC	41	129-200	TAKE APART THUMB SCREW
20	20-155	ECCENTRIC SPRING	62	62-309	CLICK SPRING
21	21-200	ECCENTRIC LEVER	62A	63-209	CLICK SPRING SCREW
21C	21-140s	ECCENTRIC LEVER	98	98-155	GEAR SLEEVE
22	22-99	ECCENTRIC SCREW	108	108-140	LEVER SPRING
22A	22-109	ECCENTRIC SCREW	149	152-200	WING NUT (2 REQ)
23	23-60	HANDLE SCREW	149A	149-200	HEX NUT (2 REQ.)
			170	170-140	PRESSED IN COLLAR
			171	171-140	ECCENTRIC PUNGER

NOTE: Many of www.pennparts.com schematics include changes that were either made by Penn, or errors found and corrected by our parts dept.

LAST UPDATE 12/14/03